

Schnitt B-B

Ansicht "Z"
View "Z"

Platine Oberteil
P C B Top Part

Platine Unterteil
P C B Bottom Part

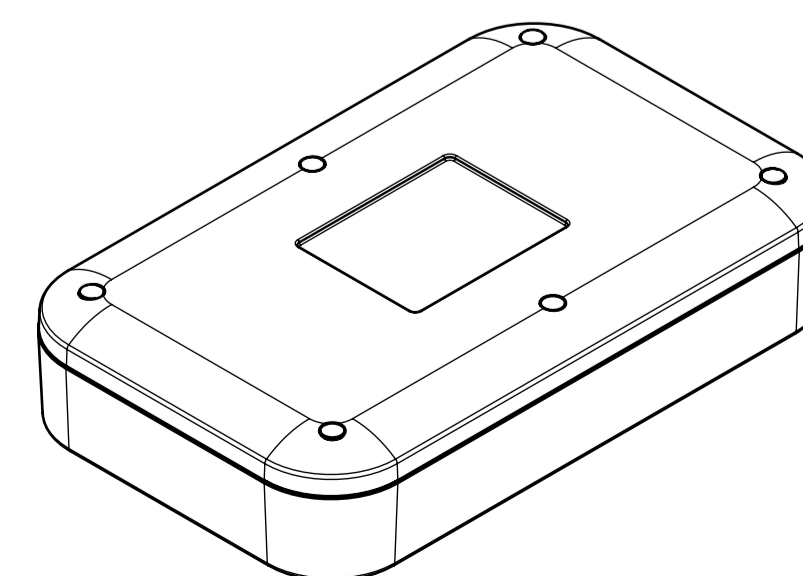
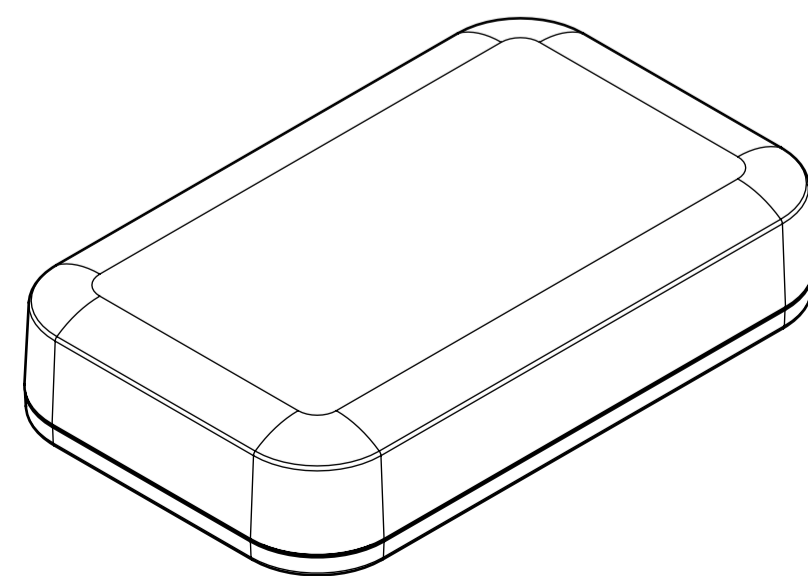
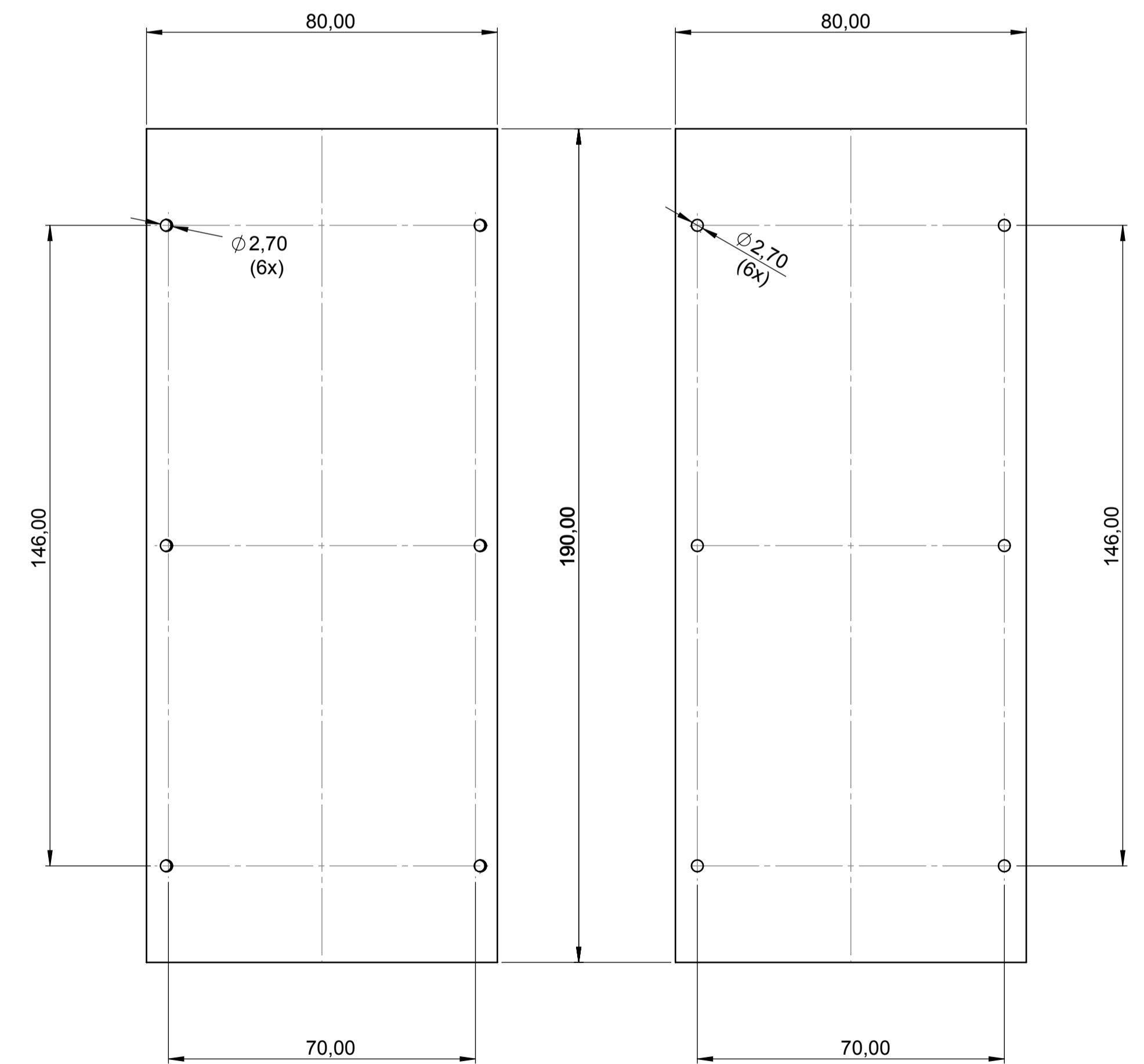
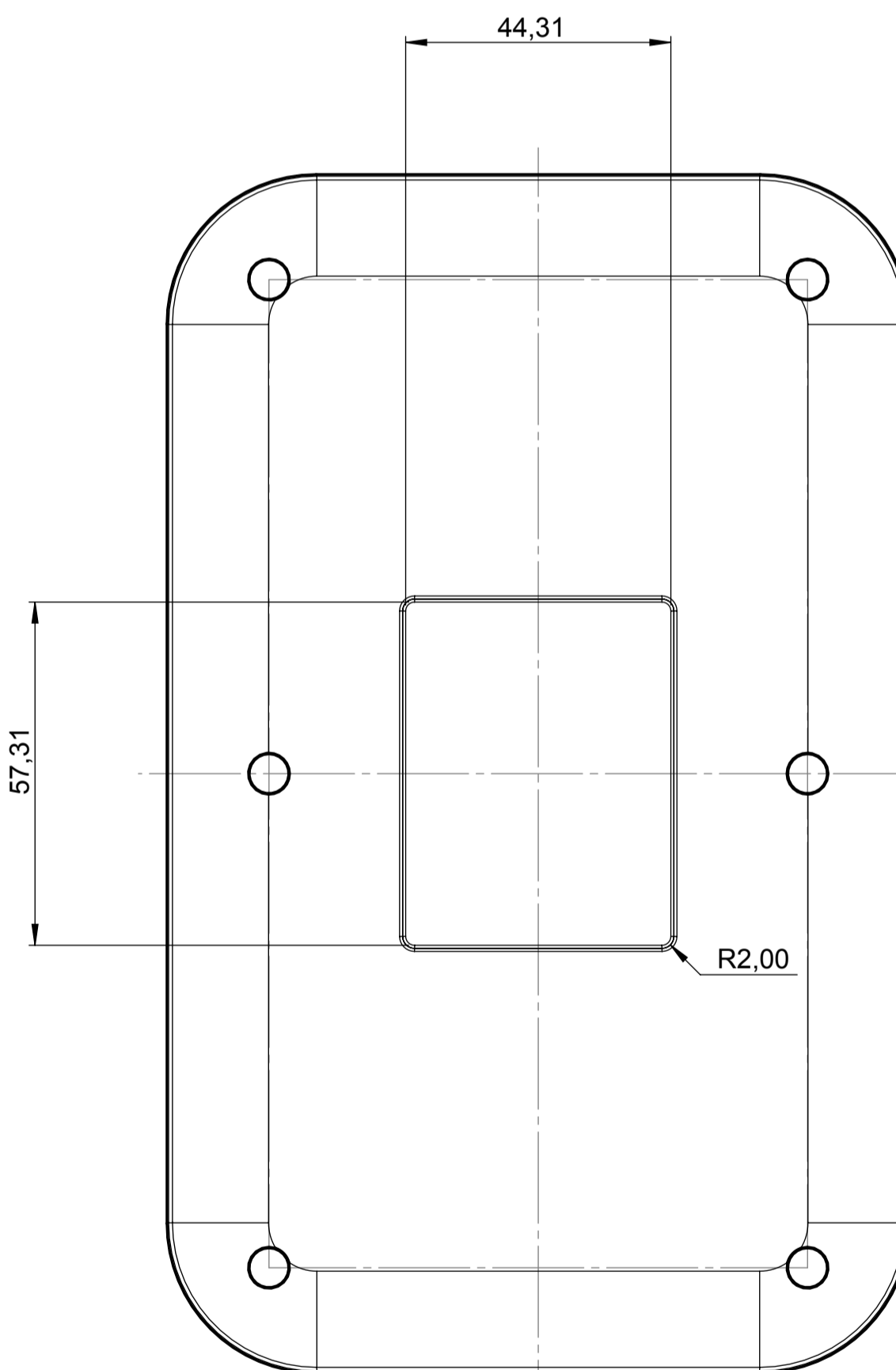
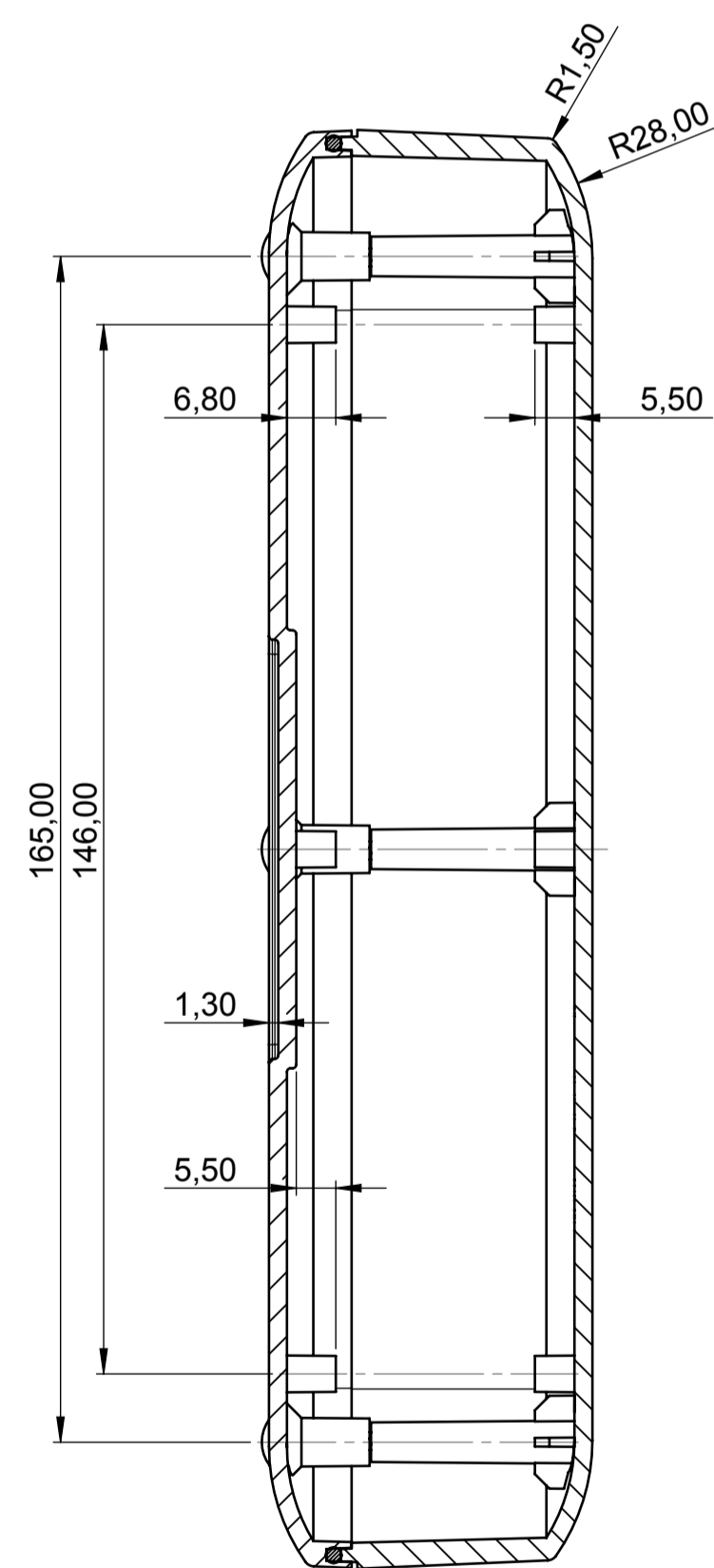
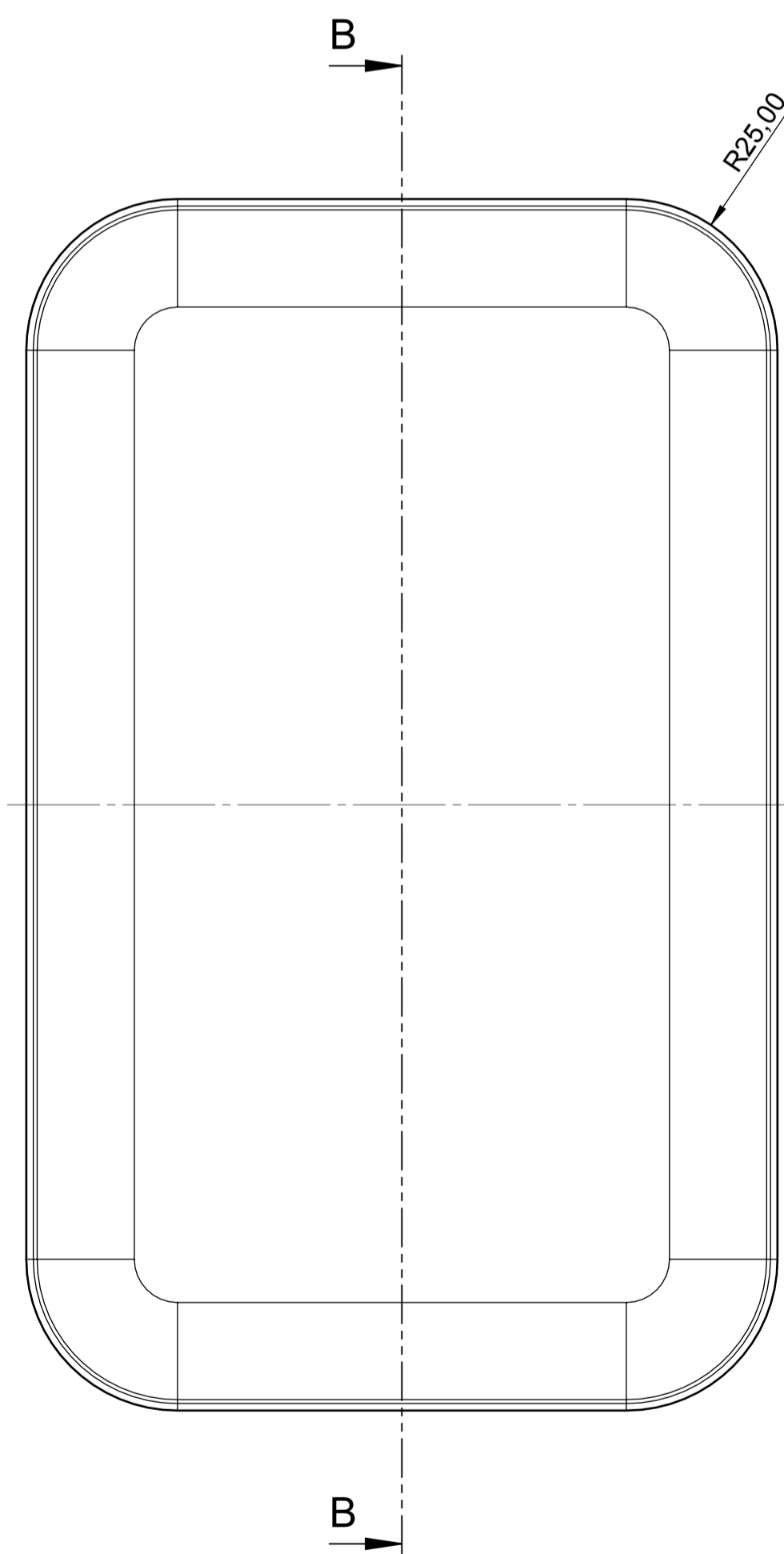

Informationskopie wird nicht aktualisiert. Copy for Information will not be updated.	Erst. am: 03.08.2016	Toleranzen:	Status:	
	Erst. von: O. Herrlich	DIN 16901 T130	ENTWICKLUNG	
	Freig. am:	Volumen:	Zeichnungsart:	
	Freig. von:	KUNDE		
Revision: 01	This document contains proprietary information of OKW Gehäusesysteme GmbH and is rendered subject to the conditions that the information be retained in confidence not be reproduced or copied and not be used or incorporated in any product.			
Technische Änderungen vorbehalten. Irrtümer oder Druckfehler begründen keinen Anspruch auf Schadensersatz. Wichtige Einbaumaße bitte direkt mit dem aktuellen Produkt ablesen. Subject to technical modification without prior notice. Typographical and other errors do not justify any claim for damages. All dimensions should be verified using an actual moulded part. Sous réserve de modifications techniques. Toute erreur ou faute d'impression ne justifie aucune demande d'indemnisation. Nous prions les clients de vérifier les dimensions des composants avec les boîtiers avant le montage.		EVOTEC 200 Ausf. I (Oberteil plan) A9461100	M 1:1 Für dieses Dokument behalten wir uns alle Urheberrechte vor. Es darf auch auszugsweise weder vervielfältigt noch Dritten in irgendeiner Form zugänglich gemacht werden.	Dateiname: 00021055