

FIRST ANGLE PROJECTION

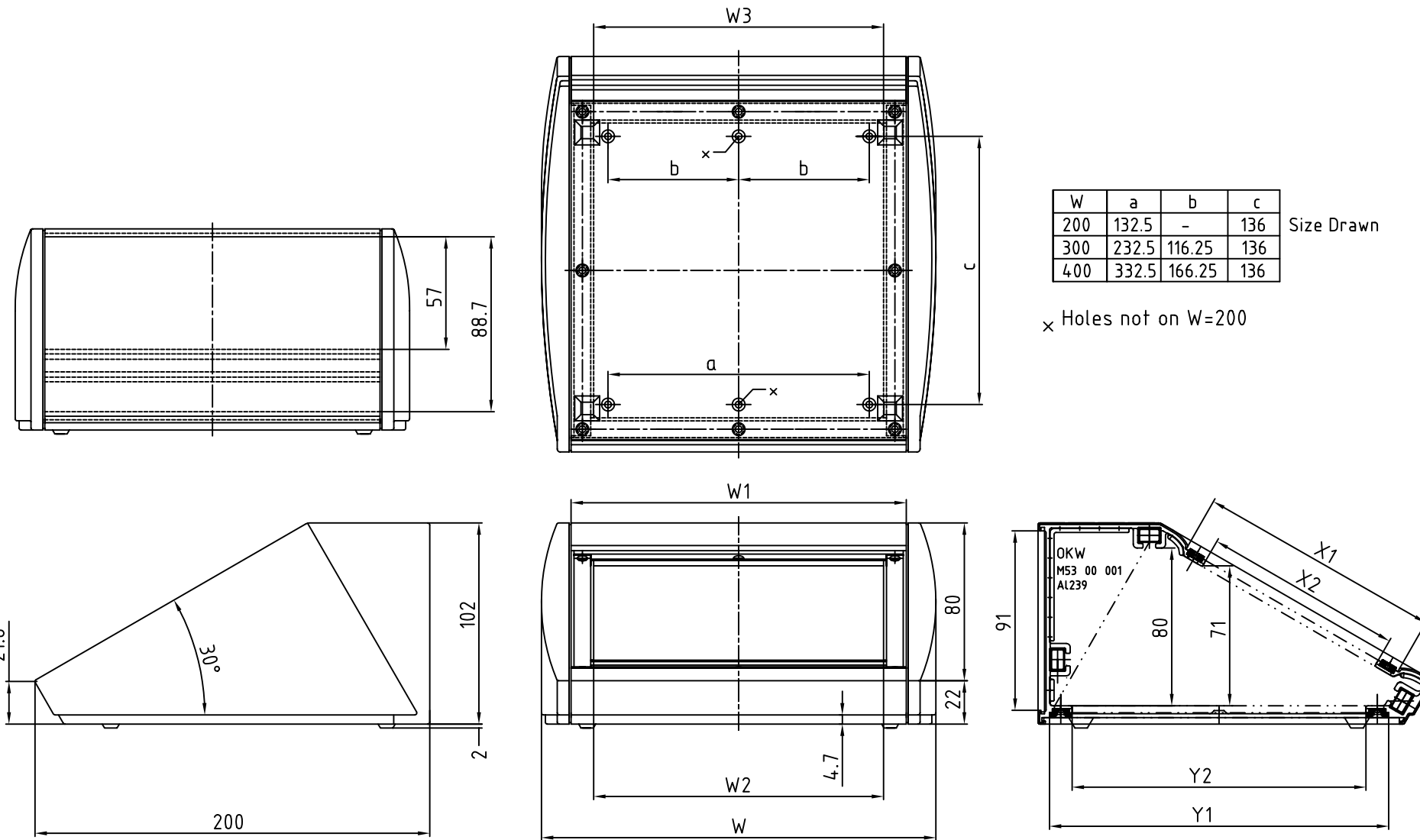

Part No.	W	W1	Size	W2	W3	X1	X2	Y1	Y2
M53 20 105	200	170	S	14.7	14.7	124	101	172	14.9
M53 30 105	300	270	M	24.7	24.7	124	101	172	14.9
M53 40 105	400	370	L	34.7	34.7	124	101	172	14.9

From May 2006, all cases are supplied with pull-up M3 fasteners to secure the front panel & base panel, rather than the original plastic M3 inserts. The quantity fitted is as follows:

Size	Part No	Front Pnl	Base Pnl
M200	M53 20 105	4	8
M300	M53 30 105	8	10
M400	M53 40 105	6	12

Tolerances unless otherwise stated: General tolerances ±0.20 Resultant tolerances between hole centers ±0.15 Tolerances on hole diameters ±0.05 Angles ± 0.5° Surface finish 32/	Required Finish: RAL 7035 L/Text Powder Coat	Scale: Drawn by: Ian Cox	ALL DIMENSIONS IN MILLIMETRES			DO NOT SCALE
	Checked By:	Drawing Number 1013	Date drawn: August '05	Material Spec. Aluminium		
www.metcase.com	METcase™ METCASE ENCLOSURES Unit 3, Mitchell Close Segensworth East, Fareham, Hampshire, PO15 5SE, UK.	Part Name Unidesk Case Assemblies			Sheet 1 of 1	
		Part Number See Table				
©OKW ENCLOSURES LTD (DATE AS SHOWN). THIS DRAWING CONTAINS PROPRIETARY INFORMATION OF OKW ENCLOSURES LTD AND IS TENDERED SUBJECT TO THE FOLLOWING CONDITIONS: THE INFORMATION BE RETAINED IN CONFIDENCE, NOT BE REPRODUCED OR COPIED, AND NOT BE USED OR INCORPORATED IN ANY PRODUCT, UNLESS PERMISSION IS OBTAINED IN WRITING FROM OKW ENCLOSURES LTD.						

Modifications	Iss
	1
Notes added about the introduction of pull-up M3 fasteners to secure front panel & base panel.	2
M300 case has 4 off extra pullup inserts to allow 8 off fixing points for the front panel. Ian - February '07.	3